

Genetic diversity of the sable (*Martes zibellina*, Mustelidae) in Russian Far East and Hokkaido inferred from mitochondrial NADH dehydrogenase subunit 2 gene sequences

Jun J. Sato^{1,*}, Tetsuji Hosoda², Alexey P. Kryukov³, Irina V. Kartavtseva³ and Hitoshi Suzuki⁴

¹ Laboratory of Animal Cell Technology, Faculty of Life Science and Technology, Fukuyama University, Higashimura-cho, Aza, Sanzo, 985, Fukuyama 729-0292, Japan

² Taikyū High School, 1985 Yuasa-cho, Arida-gun, Wakayama 643-0004, Japan

³ Institute of Biology and Soil Science, Far East Branch of Russian Academy of Sciences, Vladivostok 690022, Russia

⁴ Laboratory of Ecology and Genetics, Graduate School of Environmental Earth Science, Hokkaido University, Kita-ku, Sapporo 060-0810, Japan

Abstract. Intra-species genetic variations of the sable *Martes zibellina* (Carnivora, Mustelidae), originating from Russian Far East and Hokkaido, were assessed by using nucleotide sequences of the mitochondrial NADH dehydrogenase subunit 2 gene (976 base pairs). Evaluation of the genetic diversity of the sables demonstrated that populations in the southern Primorsky territory in Russian Far East harbors high genetic diversity. We assumed that the high genetic variations might have been due to effects of refugia, secondary admixture of allopatrically differentiated lineages, or massive anthropogenic introductions. Molecular phylogenetic (maximum likelihood and Bayesian inference approaches) and network (median joining method) analyses clarified that sables in Hokkaido was monophyletic. Bayesian-relaxed molecular dating approach estimated the date for migration of sables into Hokkaido to lie between 0.10–0.27 Myr BP. Considering the geological evidence, the Late Pleistocene was presumed to be the plausible epoch for the establishment of the sables in Hokkaido. Lower genetic diversity of the sables in Hokkaido observed in this study was probably caused by the foundation effects or anthropogenic hunting pressures. Mammalian faunal construction in Hokkaido was also discussed.

Key words: genetic diversity, Hokkaido, *Martes zibellina*, ND2, Russian Far East.

The Pleistocene is an epoch which witnessed the dynamic climate changes with glacial and interglacial cycles (e.g., Luthi et al. 2008). The impacts of the Pleistocene climate oscillations on the intra- and inter-specific genetic diversity have been well investigated for a variety of organisms in Europe (Hewitt 1996, 1999, 2000, 2001, 2004; Stewart and Lister 2001; Kadereit et al. 2004; Lister 2004; Provan and Bennett 2008; Stewart et al. 2010) and North America (Wooding and Ward 1997; Avise and Walker 1998; Avise et al. 1998; Conroy and Cook 2000; Stone et al. 2002; Lessa et al. 2003; Lister 2004; Johnson and Cicero 2004; Weir and Schluter 2004; Zink et al. 2004; Lovette 2005; Runck and Cook 2005). By contrast, northeastern Eurasia has been relatively untapped for such aims. Northeastern Eurasia has been considered free of ice-sheet during the glacial periods

(Svendsen et al. 2004). But the region was dominated by the permafrost and arid treeless vegetation (e.g., Hewitt 2000; Harrison et al. 2001; Schirrmeyer et al. 2002; Lister 2004). Such environmental alterations in the glacial periods could have affected the population dynamics of the forest-living organisms. However the effect of the Pleistocene climate change has not been fully documented on the northeastern Eurasian forest-associated species except for some species at a lower trophic level (East Asian field mouse *Apodemus peninsulae*, Serizawa et al. 2002; Sakka et al. 2010; Russian flying squirrel *Pteromys vorans*, Oshida et al. 2005; Wood lemming *Myopus schisticolor*, Fedorov et al. 2008; Siberian chipmunk *Tamias sibiricus*, Lee et al. 2008a).

The sable, *Martes zibellina*, is a forest-dwelling carnivorous species (Mustelidae, Carnivora), occupying both

*To whom correspondence should be addressed. E-mail: jsato@bt.fubt.fukuyama-u.ac.jp

coniferous and deciduous forests across northern Eurasia and expanding its distribution to the small eastern marginal island of Japan, Hokkaido (Nowak 1999; Murakami 2009; Monakhov 2011). It mainly preys on small mammals such as voles inhabiting the boreal forest (Buskirk et al. 1996; Nowak 1999; Murakami 2003). Thus the deforestation in the Pleistocene might have affected the population history of the sable, making this species one of suitable organisms for inferring the effect of the Pleistocene climatic change on the population dynamics of northeastern Eurasian species. Furthermore the phylogeographic assessment of this carnivore would provide insight into the difference in response of organisms at distinct trophic level to the Pleistocene climate changes.

There have been relatively many genetic researches for the sable in the northeastern Eurasia and Hokkaido (Balmysheva and Solovenchuk 1999a, b; Hosoda et al. 1999, 2000; Kurose et al. 1999; Murakami 2001; Murakami et al. 2004; Petrovskaya 2007; Sugimoto et al. 2009; Inoue et al. 2010; Malyarchuk et al. 2010). However, dense samplings of this species have not been attained in most of those studies, so that the genetic diversity of this species was not fully evaluated. Furthermore, only four studies have investigated both lineages from the Eurasian continent and Hokkaido (Hosoda et al. 1999, 2000; Inoue et al. 2010; Malyarchuk et al. 2010), and therefore the phylogenetic history of the Japanese sable has remained to be enlightened.

In the present study, we examined genetic diversity of the sable sampled from various localities in Russian Far East and Hokkaido (Fig. 1), based on nucleotide sequences of the mitochondrial NADH dehydrogenase subunit 2 (ND2) gene. The ND2 gene was found to possess genetic variations that would be useful for phylogeographic analyses (e.g., Sato et al. 2009a).

Materials and methods

Samples and nucleotide sequences examined

Samples analyzed in this study are listed in Appendix. In total, 70 individuals of *Martes zibellina* and one individual per following species of the same subgenus, *Martes americana*, *Martes foina*, *Martes martes* and *Martes melampus*, were examined. We determined partial nucleotide sequences of mitochondrial NADH dehydrogenase subunit 2 gene (ND2; ca. 1kb) for 69 individuals of *M. zibellina* (a homologous sequence for one more individual #TH401 was derived from Sato et

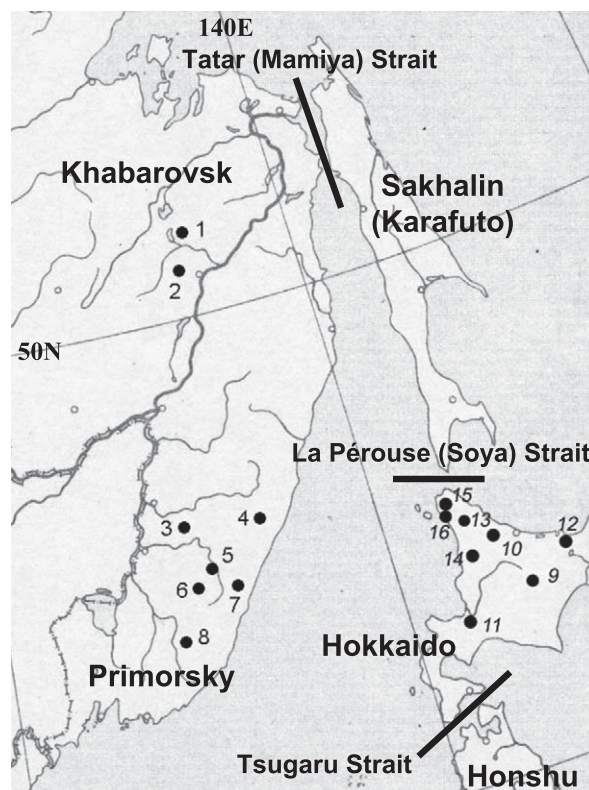

Fig. 1. A diagram for sampling localities of the sable *Martes zibellina* in Russian Far East and Hokkaido and configurations of some islands (Sakhalin [Karafuto], Hokkaido, and Honshu) and straits (Tatar [Mamiya], La Pérouse [Soya], and Tsugaru Straits). Each locality number corresponds to that used in Fig. 2 and Appendix.

al. 2009a). *M. foina* was used as an outgroup for the phylogenetic analyses on the basis of the previous supported phylogenetic hypothesis that *M. foina* was the most basal lineage within the subgenus *Martes* (e.g., Wolsan and Sato 2010). Novel sequences were deposited in the DNA databases with accession numbers AB625980–AB626048 (Appendix).

PCR amplification and sequencing strategy

Total genomic DNA was extracted from tissues preserved in ethanol using the conventional phenol–chloroform method (Sambrook and Russell 2001). The amplification was performed via polymerase chain reactions (PCRs) using an automated thermal cycler (model PC 302, ASTEC). In the PCR, we used KOD -plus- version 2 DNA polymerase kit (TOYOBO) according to the manufacturer's instructions. Each PCR mix was composed of the KOD -plus- version 2 buffer, 1.5 mM MgSO₄, 0.2 mM of each dNTP, 0.3 μM of each primer, 1.0 unit of KOD -Plus- DNA polymerase, and 0.1–0.2 μg of template total genomic DNA in a total volume of

50 μ l. Thermal cycling parameters of the PCR were as follows: a cycle of denaturation at 94°C for 2 min, 35 cycles of denaturation at 94°C for 15 sec, annealing at 50°C for 30 sec, and extension at 68°C for 1 min and a half, and a final cycle of extension at 68°C for 10 min. The primers used to amplify the ND2 gene were ND2-FelF (Yu and Zhang 2006) and ND2-melExtR (Sato et al. 2009a). As a negative control, PCRs without DNA templates were also performed and no amplification was detected in the negative control PCR products. The sequence reaction of the PCR products was carried out using the BigDye Terminator Cycle Sequencing kit v3.1 (ABI) and primers of ND2-FelF and ND2-CarF (Yu and Zhang 2006), followed by automated sequencing on an ABI3130 genetic analyzer.

Multiple alignments and applied data matrices

The ND2 sequences generated in this study and collected from the DDBJ DNA database were aligned manually since the absence of insertions and deletions made alignment straightforward. The assembled data matrices we ultimately used are available from TreeBASE (<http://www.treebase.org/treebase/index.html>) under study accession number S11435.

Phylogenetic and demographic analyses

Phylogenetic trees were inferred by the maximum likelihood (ML; Felsenstein 1981) and Bayesian inference (BI; Huelsenbeck et al. 2001) approaches. ML analyses were performed with the program GARLI version 1.0 (Zwickl 2006) using the best fit model of nucleotide substitution determined by Akaike Information Criterion (AIC) available in the program Modeltest version 3.7 (Posada and Crandall 1998; see also Posada and Buckley 2004). The optimal model was GTR + I. ML tree was inferred from heuristic searches via five runs of the genetic algorithm with 50,000 generations of a mutation-selection-reproduction cycle. The starting tree was generated from the ML stepwise-addition-sequence option. All the other parameters were set by default. Clade supports were assessed by nonparametric bootstrap analyses (BP; 1,000 replicates; Felsenstein 1985).

BI analyses were performed with the program MrBayes version 3.1.2 (Huelsenbeck and Ronquist 2001; Ronquist and Huelsenbeck 2003), using best-fit nucleotide-substitution models inferred via AIC implemented in MrModeltest version 2.2 (Nylander 2004). The applied model was GTR + I. Model parameters were estimated as part of the analyses. Trees were generated using

the Metropolis-coupled Markov-chain Monte-Carlo (MCMCMC) algorithm. The algorithm was run twice to assure convergence. Each run consisted of four simultaneous chains, one cold and three incrementally heated, and started from a random tree. Chains were run for 5 million generations and sampled once every 100 generations. The first 12,500 (25%) trees were discarded as burn-in. The remaining post-burn-in trees were used to construct a 50% majority-rule consensus tree and to calculate posterior probabilities (PP) of inferred clades. Average standard deviation of split frequencies (ASDSF; an indicator of convergence of MCMCMC cycles) was 0.004015, the value of which was under the recommended maximum value for convergence (0.01) in the instructions of MrBayes version 3.1.2. The analyses of the generated parameter files with Tracer version 1.5 (Rambaut and Drummond 2007) indicated that log-likelihood scores for all of the parameters had converged on a stationary distribution. Potential scale reduction factor of 1.0 and effective sample size (ESS) of more than 500 for all parameters also confirmed that the convergence had been reached and collected tree samples are enough to construct BI tree.

In order to infer the relationships of the obtained haplotypes, the median-joining network was also reconstructed by using the program Network version 4.6 (Bandelt et al. 1999).

Haplotype diversity (h) and nucleotide diversity (π) were evaluated for individuals from each geographic source (possible population). The possibility of the demographic expansions for each population was assessed by Tajima's D (Tajima 1989) and Fu's F_s (Fu 1997) statistics by using the program DnaSP version 5 (Librado and Rozas 2009). In the same program, the demographic history was also inferred by the mismatch distribution approach (Rogers 1995).

Divergence time estimation

To estimate the divergence times for the origins of observed lineages of the sables, we adopted the Bayesian relaxed molecular-clock dating approach as implemented in the program BEAST, version 1.6.1 (Drummond and Rambaut 2007). We used the approach considering rate variation among different branches, where the rates on each branch were independently drawn from a lognormal distribution and uncorrelated (Drummond et al. 2006). We used the program BEAUti, version 1.6.1 (provided in the BEAST package), to make input file for the BEAST program, where we set the substitution model for the

sequence evolution, priors, and conditions of Markov Chain Monte Carlo (MCMC) for estimating posterior distributions of the time to the most recent common ancestor (MRCA) of sable individuals. We set the GTR + I for the substitution model as selected above. We selected the coalescent model with constant population size as a prior on phylogeny. Five independent MCMC analyses were run for 10 million generations with trees sampled every 1,000 generations. Each log file was checked to confirm the convergence to the stationary posterior distribution and the sufficient effective sample size (ESS) of each parameter in the program Tracer. The log files of five runs were then combined with the first 25% of the sampled parameters discarded as burn-in. We obtained sufficient ESS values exceeding 100 for all parameters, in particular over 400 for the divergence-time parameters of each node representing the MRCA of the sable individuals. We provided parameter estimates based on the combined samples from the five independent runs.

Multiple calibration points were set on the basis of the fossil records. The fossil information was adopted in the form of the lognormal prior distribution in line with the recommendation of Ho (2007) and Ho and Phillips (2009). The values of the time constraints based on fossil evidence were set to the zero-offset of the lognormal distribution as the minimum bound. The mean of the lognormal distribution was unavoidably set to somewhat subjective values (Ho 2007). For calibrations, we used two time constraints as minimum bounds. First, 3.3 Ma was applied to the MRCA of the subgenus *Martes* (*M. americana*, *M. foina*, *M. martes*, *M. melampus*, and *M. zibellina*), based on the earliest fossil remains of the subgenus, *M. wenzensis* (see Sato et al. 2003 for more detail). The mean value was set to 1.0. The standard deviation was set so that the upper limit of the 95% Confidence Interval (CI) took the value of 5.4, because the stem lineage of the subgenus *Martes* was estimated to have originated at 4.7–5.1 Ma (Koepfli et al. 2008) and 5.4 Ma (Sato et al. 2009b). Second, we used the fossil record of extinct *Martes vetus*, which has been regarded as an ancestor of *M. martes* and *M. zibellina* (e.g., Sato et al. 2003). This species chronologically ranges from 1.8 Ma to 300–400 ka (Wolsan 1993; Sato et al. 2003). We therefore set 300 ka as a minimum bound for the MRCA of *M. martes* and *M. zibellina*. And we used 1.8 Ma as the upper limit of the 95% CI. The mean value was set to 1.0.

Results

Sequence variations and demographic features

A total of 13 ND2 haplotypes were identified among 70 individuals of sables, of which 11 and 2 haplotypes were observed in individuals from Russian Far East and Hokkaido, respectively (Table 1 and Appendix). Variable and parsimony informative sites for whole dataset of sables were 22 and 18, respectively. Haplotype and nucleotide diversities were 0.86 and 0.00529, 0.82 and 0.00511, and 0.36 and 0.00036 for the total, Russian Far East, and Hokkaido populations, respectively (Table 1). 4 individuals from Khabarovsk territory showed only two haplotypes (Hap1 and Hap9). Both haplotypes were also observed in the southern localities in Primorsky territory. Sables from the Primorsky territory had different proportions of haplotypes. Each locality possesses multiple haplotypes except for locality 7 where only one individual was examined. Hap1 was the most frequent haplotype and shared by three out of six localities in Primorsky territory (localities 5, 6, and 8). Hokkaido sables maintained two specific haplotypes (Hap4 and Hap5) which were not detected in the continent. Hokkaido population of sables harbored fewer numbers of haplotypes and showed less genetic diversity than continental populations (Table 1).

In all cases of the examined locality groupings, Tajima's D and Fu's *F_s* values showed positive values (Table 1) except for Tajima's D value for the Khabarovsk population. The departure from the neutrality by population expansion or positive selection was not detected in the present datasets (Table 1). The analysis of mismatch-distribution showed bimodal distribution for the Primorsky populations encompassing localities 3–8 (data not shown). Both the positive Tajima's D and Fu's *F_s* values and the multimodal mismatch distribution indicate that the population of the sables in the Primorsky territory has been stable.

Phylogenetic inference

Both maximum likelihood and Bayesian inference phylogenetic approaches produced an identical topology (Fig. 2). The monophyly of the examined sables was recovered with high support values (Fig. 2; ML BP = 94% and BI PP = 1.0). And the close phylogenetic affinity between the sable and the pine marten *Martes martes* was also strongly supported (Fig. 2; ML BP = 92% and BI PP = 1.0). Within the lineage of the sable, four major lineages (phylogroups) were detected among

Table 1 Statistics of sable populations in Russian Far East and Hokkaido

Population ^a	Sample numbers	Haplotype numbers	h ^b	π ^c	Tajima's D ^d	Fu's <i>F_s</i>
Total	70	13	0.86	0.00529	0.40056	0.949
Russian Far East (1–8)	60	11	0.82	0.00511	0.69062	1.625
Khabarovsk (1–2)	4	2	0.50	0.00410	-0.82407	3.526
Primorsky (3–8)	56	11	0.84	0.00516	0.67961	1.494
Hokkaido (9–16)	10	2	0.36	0.00036	0.01499	0.417

^a locality numbers in parentheses are the same as in Fig. 1 and Appendix.

^b h: haplotype diversity.

^c π : nucleotide diversity.

^d All of the Tajima's D and Fu's *F_s* values were statistically not significant ($P > 0.1$).

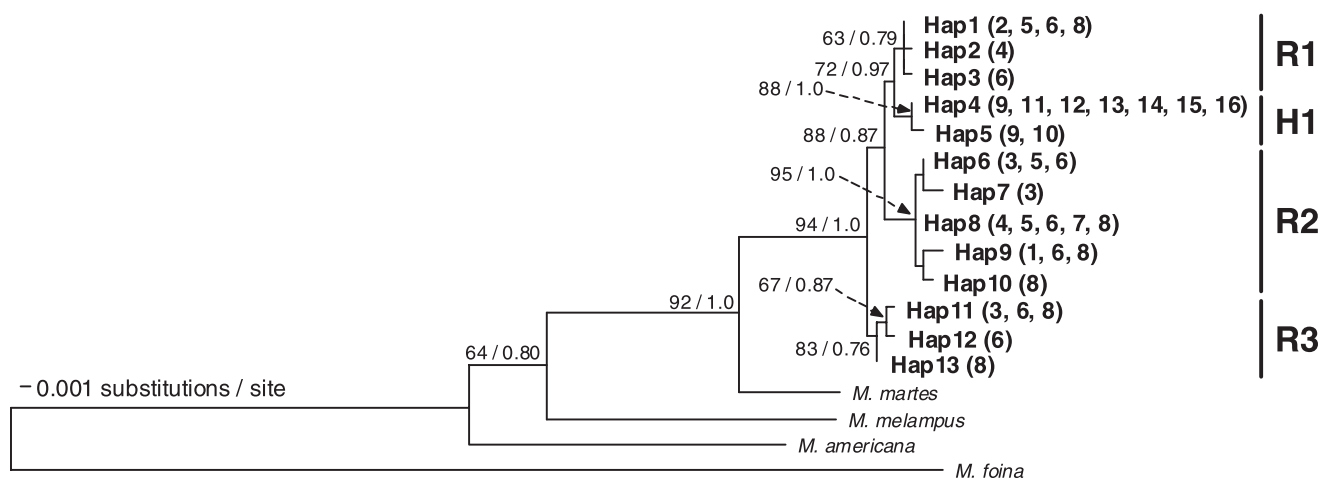

Fig. 2. Phylogenetic relationships of the sables *Martes zibellina* and the other species of the subgenus *Martes* inferred from maximum likelihood analyses of the ND2 gene sequence (976 bp). The negative log likelihood scores for optimal ML topology (-lnL) was -2220.330584. *Martes foinea* was used as an outgroup. Numbers attached to nodes are ML bootstrap proportions (1,000 replicate) to the left and BI posterior probability to the right. The numbers in parentheses after each haplotype code (e.g., Hap1) indicates the same sampling locality as in Fig. 1 and Appendix. Vertical thick line represents observed phylogroups.

the examined individuals of sables, as designated R1, R2, R3, and H1 in Fig. 2. While sables originated from Hokkaido formed a monophyly with strong support values (Fig. 2; ML BP = 88% and BI PP = 1.0), no geographic structure was identified in the other three continental lineages (R1, R2, and R3). Each lineages contained individuals derived from several localities in the Khabarovsk and/or Primorsky territories. The R1 and R2 lineages were observed in both two territories, while the R3 lineage was shared by several localities in the Primorsky territory. Although the proportion of major three phylogroups was different in each locality in the Primorsky territory, no phylogroup was fixed in a locality, suggesting substantial gene flows among these localities in the Primorsky territory. We therefore treated individuals from the six examined localities in Primorsky territory as one population for comparison of

genetic diversity with Hokkaido (Table 1). We did not include Khabarovsk individuals in the same population of the Primorsky territory because of the relatively long geographical distance between the territories. Median-joining network analyses also clarified the primary four phylogroups (Fig. 3). Intra-phylogroup variations were shown by one to four mutation steps within each R1, R2, R3, and H1 lineage. Inter-phylogroup variations were represented by three to 11 mutation events. The most abundant haplotype in the continent (Hap1) was the genetically closest to haplotypes in Hokkaido (Hap 4 and Hap5) with three mutation events through one unobserved haplotype (median vector).

Chronological inference

The divergence time between *Martes martes* and *Martes zibellina* was estimated to be 1.16 Myr BP (mil-

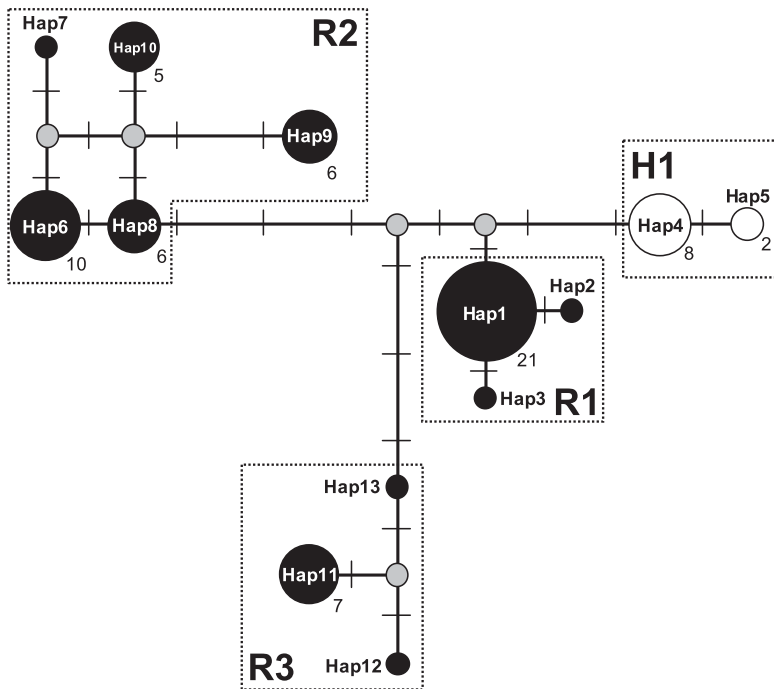

Fig. 3. Median-joining network of the obtained haplotypes for sables *Martes zibellina*. The designation of haplotypes (Hap1–13) and phylogroups (R1, R2, R3, and H1) was the same as in Fig. 2. Node sizes are proportional to haplotype frequencies and the number of the samples was attached near each node when there are more than two individuals. Slashes on branches between nodes indicated mutations. Closed nodes are haplotypes derived from Russia and open nodes are those from Hokkaido. Gray nodes indicate unobserved haplotypes (often called median vectors).

lion years before present) with 95% credibility interval (CI = 0.76–1.62). The date for the most recent common ancestor (MRCA) of the examined sables, corresponding to the divergence time between R3 and the other phylogroups, was inferred to be 0.54 Myr BP (CI = 0.21–0.95). The divergences of the major four lineages of the sables were estimated to have occurred at 0.54 Myr BP (CI = 0.21–0.95) as described above, 0.44 Myr BP (CI = 0.15–0.79) for R2 vs R1-H1, and 0.27 Myr BP (CI = 0.09–0.52) for R1 vs H1. The dates for MRCA of each lineage could be estimated by using intra-phylogroup variations. Such an approach produced the results that the date for the MRCA of R1, R2, R3, and H1 phylogroups were 0.15 Myr BP (CI = 0.04–0.30), 0.23 Myr BP (CI = 0.07–0.45), 0.20 Myr BP (CI = 0.03–0.46), and 0.10 Myr BP (CI = 0.02–0.23), respectively. The sable lineage in Hokkaido was generated by the divergence from R1 phylogroup at 0.27 Myr BP, but the appearance of the MRCA of the Hokkaido sables was estimated at more recent age (0.10 Myr BP).

Discussion

Maximum-likelihood and Bayesian-inference phylogenetic trees and the Median-Joining network based on the mitochondrial ND2 gene sequences (976 bp) demonstrated major four phylogroups of sables in Russian Far

East and Hokkaido, as designated R1, R2, R3, and H1 (Fig. 2). While the sables in Hokkaido formed a monophyly, those in the continent did not show any geographical genetic structures. On the basis of haplotype and nucleotide diversities (Table 1), sables from the southern Primorsky territory showed more genetic diversity than those from the northern Khabarovsk territory although very small sample size from the latter requires cautions for the interpretations. Mismatch distribution analyses showed the multimodal distribution for the population in the southern Primorsky territory, implying that the sable population in the Primorsky territory has been stable (for the interpretation of multimodal distribution, see Harpending et al. 1998). Positive values of Tajima's *D* and Fu's *F_s* were also consistent with this implication. Bayesian relaxed molecular-clock analyses showed that the divergence times among the major sable lineages were estimated to be 0.27–0.54 Myr BP, suggesting that genetic divergence among the sable lineages occurred during the Middle Pleistocene period in the continent. The evidence described above supports the notion that genetic diversity of sables collected from the Primorsky territory might have been affected by the refugia effect in the Pleistocene period. Below, we discuss the cause of the high extent of the genetic diversity of sables in the Primorsky territory in the light of natural and human-mediated factors.

Genetic diversity of the sable in the Russian Far East

In the present study, the population from southern Primorsky territory was demonstrated to harbor higher genetic diversity with 11 haplotypes while there were only two haplotypes in the northern Khabarovsk territory although we can not rule out the possibility of sampling bias. More genetic diversity in the southern populations and less in the northern ones have generally been known as “southern richness and northern purity” (e.g., Hewitt 1999; but see Provan and Bennett 2008 for exceptions). This observation has been considered to be attributed to effects of refugia usually located at the lower latitude in the glacial period and founder colonization events at the higher latitude in the post-glacial period (e.g., Hewitt 1999). Refugia would have been less affected by severe climatic alterations in glacial periods and induced allopatric differentiations into distinct genetic lineages. If such scenario is applicable to our study, the consistent trends observed among European, North American, and the present northeast Eurasian populations would exemplify the ubiquitous importance of the effect of the Pleistocene climate changes on population genetic divergences. The refugia hypothesis has been supported in many studies of the northeast Eurasian species by showing higher genetic diversity in the Primorsky territory (Serizawa et al. 2002; Oshida et al. 2005; Lee et al. 2008b; Malyarchuk et al. 2009; Kryukov 2010; Sakka et al. 2010; Haring et al. 2011). The paleoenvironmental study documented that the southern limit of the continuous permafrost distribution during the last glacial period existed in the Primorsky territory (Ono 1991). Refugia could have been created in such peri-permafrost places. Alternative explanation for the higher genetic diversity is the secondary admixture among allopatrically evolved populations (e.g., Avise 2000). Multimodal distribution of the mismatch analyses as observed in this study can also suggest the secondary admixture (Avise 2000). It is however difficult to discriminate between “biodiversity hot spot (refugia)” and “melting pot (admixture zone)” (Petit et al. 2003; Provan and Bennett 2008). More samplings from other geographic localities are required to test these possibilities. Another important issue that should be considered in evaluating genetic diversity of the sable is their massive anthropogenic introduction history. There have been some literatures reporting introductions of the sable into Russian Far East by human (Pavlov et al. 1973; Bobrov et al. 2008; Monakhov 2011) and their genetic influences (Balmysheva and Solovenchuk 1999a; Petrovskaya 2007). The effect by

the sable introductions on the higher genetic diversity of the Primorsky populations is therefore highly probable. This issue also highlights the need to increase more sampling from diverse areas.

Endemism and genetic diversity of the sable population in Hokkaido

The sable in Hokkaido is known as a local subspecies classified as *Martes zibellina brachyura* based on morphological criteria (Anderson 1970; Wozencraft 2005). But the origin of this subspecies has not been fully demonstrated partly due to scarce comparisons to the continental individuals in previous studies. In Malyarchuk et al. (2010) and Inoue et al. (2010), the Hokkaido individuals of the sable did not form a monophyly. Malyarchuk et al. (2010) showed that the clade consisted of the Japanese sables also included Magadan sables, but did not explain the reason for such mixed clade. Inoue et al. (2010) also did not obtain the monophyly of the Hokkaido lineage and concluded that the Hokkaido population was not genetically well-differentiated from continental populations after immigration in the last glacial period. But the relationships of the Hokkaido sables to the continental ones in their study were supported with very low reliabilities. Moreover they did not estimate divergence times with their empirical data. Therefore not only the phylogenetic history but also the endemism of the sable population in Hokkaido has not been properly evaluated. By contrast, the present study strongly supports the monophyly of sables from various regions in Hokkaido (Fig. 2), showing that the origin of the extant Japanese sables was caused by only one historical event. Although it is impossible to exclude the possibility of too few samplings of sables from Hokkaido, the result is in congruence with Hosoda et al. (1999, 2000) showing the monophyly of the Hokkaido sables. And the possible migration time estimate of 0.10–0.27 Myr BP was older than the last glacial period assumed by Inoue et al. (2010). It is therefore appropriate to conclude that the sables in Hokkaido possess some genetic endemism.

The results from the present study and Inoue et al. (2010) are mutually complementary in assessing differences in genetic diversities between the Hokkaido and the continental populations. The present study examined 60 Russian and 10 Hokkaido individuals, while Inoue et al. (2010) treated 3 Russian and 49 Hokkaido individuals. Although the component of examined specimens (Russian or Hokkaido) was different from each other,

both studies showed lower haplotype and nucleotide diversities of the Hokkaido population (Table 1). In agreement with such a trend, Serizawa et al. (2002) clarified that Hokkaido population of East Asian field mouse, *Apodemus peninsulae*, possessed lower genetic diversity. Such low genetic diversity in a population of an island has generally been ascribed to genetic bottleneck in foundation and subsequent inbreeding (Frankham et al. 2010). On the other hand, Hokkaido was located in a transitional zone between continuous and discontinuous permafrost in Late Pleistocene (Ono 1991), suggesting that Hokkaido, located at the similar latitude to Russian Far East, could have harbored refugia. In fact, Kurose et al. (1999) recognized Hokkaido as a refugium for *Martes zibellina* in the last glacial age of the Quaternary. One could therefore suppose populations in Hokkaido shows higher genetic diversity because Hokkaido may have had multiple refugia and/or it may have received repeated immigrants from the continent during cyclic glacial periods in the Pleistocene. For instance, the brown bears *Ursus arctos* in Hokkaido show three genetically distinct lineages probably immigrated during different periods (Matsushashi et al. 1999). However the present result is contrary to the expectation from the refugia hypothesis. Although Hokkaido might have played a role in creating refugia, the effects of refugia would have been confounded by genetic bottleneck and inbreeding in an island of Hokkaido. Moreover it cannot be ruled out that heavy hunting pressures for the sable fur industry might have devastated the genetic diversity of the sable populations in Hokkaido (Inukai 1975). We assume that various natural and anthropogenic factors in their population history might have eliminated signs of refugia, leading to the observation of the lower genetic variation in the Hokkaido sables.

Mammalian faunal construction in Hokkaido

This study supported the view that Hokkaido functioned as an effective geographic region for generating specific evolutionary lineage. Although the level of endemism is lower in Hokkaido as suggested by Suzuki (2009), the lineage in Hokkaido nevertheless harbors endemism to some extent. Comparing divergence times between lineages in continent and Hokkaido across a various species, the role of Hokkaido on the generation of endemism can be evaluated. There are many terrestrial and arboreal mammalian species whose distributions are similar to the sable (present in the Eurasian continent and Hokkaido and absent in the other parts of

the Japanese archipelagos; see Dobson 1994). Those species might have shared the phylogeographic history on the same distributions. Thus, taken together, we could test their consistent historical process and understand the way of the mammalian faunal constructions in Hokkaido. Below we outlined the possible migration times of a variety of mammals in Hokkaido mainly estimated from molecular data: 1) Sakka et al. (2010) estimated the divergence time between Hokkaido and the continental lineages of East Asian field mouse, *Apodemus peninsulae*, to be ca. 0.1 Myr BP; 2) As in the case of the sable, local population of the mountain here, *Lepus timidus*, in Hokkaido is considered a subspecies, *L. t. ainu* and the divergence of this local subspecies from the continent was estimated to have occurred at 0.5–0.6 Myr BP (Yamada et al. 2002; Yamada 2009); 3) Similarly the population of the Russian flying squirrel, *Pteromys volans*, in Hokkaido was classified as *P. v. orii* (Kuroda 1921), which was considered to have diverged from continental counterpart at 0.2–0.4 Myr BP (Oshida et al. 2005); 4) Eurasian red squirrel, *Sciurus vulgaris*, in Hokkaido is also described as a subspecies, *S. v. orientis* (Imaizumi 1960; Tamura 2009). Based on geological evidence, Oshida and Masuda (2000) concluded that the Hokkaido population had been isolated since Late Pleistocene; 5) Ohdachi et al. (2001) examined the phylogeographic history of four *Sorex* species bearing the similar distribution to the sable, in which the immigration date of the long-clawed shrew *S. unguiculatus* into Hokkaido was assumed to be 24–25 ky (kilo years) BP on the basis of the geological evidence, while that of the Eurasian common shrew *S. caecutiens* was older than the most recent geological separation between Hokkaido and the continent; 6) Iwasa et al. (2000, 2002) clarified monophyly of the Hokkaido lineages of gray red-backed vole *Myodes rufocanus* and northern red-backed vole *Myodes rutilus*. They also estimated the divergence times of *M. rufocanus* and *M. rutilus* in Hokkaido from the continental lineages to be a few and 0.6–1.2 Myr BP, respectively; 7) Matsushashi et al. (1999, 2001) elucidated that there were three lineages of the brown bear in Hokkaido and suggested that three migrations from the continent should have shaped the present phylogeographic patterns of this species. Korsten et al. (2009) inferred that one of the three Hokkaido lineages migrated from the continent after the last glacial maximum (LGM; 23–15 ky BP), while the other two had their origin on the continent before the LGM.

Except for a few, almost all of the examples described

above shows that the lineage in Hokkaido diverged from that in the continent during the period earlier than the Late Pleistocene. It has not however escaped our notice that the divergence times between lineages in the continent and Hokkaido is not necessarily the date for their arrival at Hokkaido. The arrival time may be more recent than the split time between continental and Hokkaido lineages. We suppose that the date for the dispersals into Hokkaido would lie between two extreme time estimates below. The date estimated by comparing continental and Hokkaido lineages could be the maximum age of the migration time, while that estimated by the MRCA approach the minimum age. In the present study, the maximum and minimum migration times of sables in Hokkaido were estimated to be 0.27 and 0.10 Myr BP, respectively. We propose that the minimum estimate by the MRCA approach would be closer to the migration time of the sable because of two circumstantial evidences below. First, the Tatar (Mamiya) and La Pérouse (Soya) Straits are considered to have been available for migrations from continent to Sakhalin (Karafuto) and from Sakhalin to Hokkaido, respectively, in both Middle (781–126 ky BP) and Late (126–10 ky BP) Pleistocene periods, but the Tsugaru Strait running between Hokkaido and Honshu islands was only available for dispersals until Middle Pleistocene and not in the Late Pleistocene (Ohshima 1990, 1991, 1992; Millien-Parra and Jaeger 1999). Second, sables are not present in Honshu. A long-distance disperser such as sables could have migrated into Honshu, if the connection between Hokkaido and Honshu was established. Thus the Late Pleistocene is the plausible period for establishment of the sable population in Hokkaido. The arrival of the sable would have been too late to cross the Blakiston's line (faunal border present in the Tsugaru Strait; see Fig. 1). In addition, estimates of migration times among species described above are different from each other. It may suggest that the faunal community structure in Hokkaido was labile during the Quaternary. This is in accordance with the fossil evidence of Kawamura (1991) who described considerable faunal changes with extinction and colonization occurred in the Late Pleistocene. Ecological community on Hokkaido would have been optimized in every faunal succession. And such chances would have created transitory food webs, ultimately leading to the modern predator vs prey interactions such as sables vs chipmunks, field mice, flying squirrels, shrews, squirrels, voles, or other mammals in Hokkaido (Murakami 2003).

Acknowledgments: We are grateful to Mitsuhiro Hayashida, Momoki Kawabe, Gota Kinoshita, and Shigeki Watanabe for providing tissue samples of sables in Hokkaido and Vyacheslav Rozhnov for the sample of *M. martes*. We thank Kotaro Ishida, Mitsuo Nunome, Morihiko Tomozawa, Kimiyuki Tsuchiya, and Shumpei P. Yasuda for valuable discussions. We also thank Mieczyslaw Wolsan for his valuable comments about the fossil evidence of *Martes wenzensis* and *Martes vetus*. This work was supported by the Heiwa Nakajima Foundation (grant of Jun J. Sato).

References

- Anderson, E. 1970. Quaternary evolution of the genus *Martes* (Carnivora, Mustelidae). *Acta Zoologica Fennica* 130: 1–132.
- Avice, J. C. 2000. *Phylogeography—The History and Formation of Species*. Harvard University Press, Cambridge, Massachusetts and London, England, 447 pp.
- Avice, J. C. and Walker, D. 1998. Pleistocene phylogeographic effects on avian populations and the speciation process. *Proceedings of the Royal Society B: Biological Sciences* 265: 457–463.
- Avice, J. C., Walker, D. and Johns, G. C. 1998. Speciation durations and Pleistocene effects on vertebrate phylogeography. *Proceedings of the Royal Society B: Biological Sciences* 265: 1707–1712.
- Balmysheva, N. P. and Solovenchuk, L. L. 1999a. Genetic variation of the mitochondrial DNA gene encoding cytochrome *b* in the Magadan population of sable *Martes zibellina* L. *Russian Journal of Genetics* 35: 1252–1257.
- Balmysheva, N. P. and Solovenchuk, L. L. 1999b. Association between mutations of mitochondrial DNA genes for cytochrome *b* and NADH dehydrogenase 5/6 in sable *Martes zibellina* L. *Russian Journal of Genetics* 35: 1681–1686.
- Bandelt, H.-J., Foster, P. and Röhl, A. 1999. Median-joining networks for inferring intraspecific phylogenies. *Molecular Biology and Evolution* 16: 37–48.
- Bobrov, V. V., Warshavsky, A. A. and Khlyap, L. A. 2008. *Alien Mammals in the Ecosystems of Russia*. KMK Scientific Press Ltd., Moscow (in Russian).
- Buskirk, S. W., Ma, Y., Xu, L. and Jiang, Z. 1996. Diets of and prey selection by sables (*Martes zibellina*) in northern China. *Journal of Mammalogy* 77: 725–730.
- Conroy, C. J. and Cook, J. A. 2000. Phylogeography of a post-glacial colonizer: *Microtus longicaudus* (Rodentia: Muridae). *Molecular Ecology* 9: 165–175.
- Delisle, I. and Strobeck, C. 2005. A phylogeny of the Caniformia (order Carnivora) based on 12 complete protein-coding mitochondrial genes. *Molecular Phylogenetics and Evolution* 37: 192–201.
- Dobson, M. 1994. Patterns of distribution in Japanese land mammals. *Mammal Review* 24: 91–111.
- Drummond, A. J. and Rambaut, A. 2007. BEAST: Bayesian evolutionary analysis by sampling trees. *BMC Evolutionary Biology* 7: 214.
- Drummond, A. J., Ho, S. Y. W., Phillips, M. J. and Rambaut, A. 2006. Relaxed phylogenetics and dating with confidence. *PLoS Biology* 4: e88.
- Fedorov, V. B., Goropashnaya, A. V., Boeskorov, G. G. and Cook, J. A. 2008. Comparative phylogeography and demographic history of the wood lemming (*Myopus schisticolor*): implications for late

- Quaternary history of the taiga species in Eurasia. *Molecular Ecology* 17: 598–610.
- Felsenstein, J. 1981. Evolutionary trees from DNA sequences: A maximum likelihood approach. *Journal of Molecular Evolution* 17: 368–376.
- Felsenstein, J. 1985. Confidence limits on phylogenies: An approach using the bootstrap. *Evolution* 39: 783–791.
- Frankham, R., Ballou, J. D. and Briscoe, D. A. 2010. *Introduction to Conservation Genetics* 2nd ed. Cambridge University Press, Cambridge, 618 pp.
- Fu, Y. X. 1997. Statistical tests of neutrality of mutations against population growth, hitchhiking and background selection. *Genetics* 147: 915–925.
- Haring, E., Sheremetyeva, I. N. and Kryukov, A. P. 2011. Phylogeny of Palearctic vole species (genus *Microtus*, Rodentia) based on mitochondrial sequences. *Mammalian Biology* 76: 258–267.
- Harpending, H. C., Batzer, M. A., Gurven, M., Jorde, L. B., Rogers, A. R. and Sherry, S. T. 1998. Genetic traces of ancient demography. *Proceedings of the National Academy of Sciences* 95: 1961–1967.
- Harrison, S. P., Yu, G., Takahara, H. and Prentice, I. C. 2001. Diversity of temperate plants in east Asia. *Nature* 413: 129–130.
- Hewitt, G. 2000. The genetic legacy of the Quaternary ice ages. *Nature* 405: 907–913.
- Hewitt, G. M. 1996. Some genetic consequences of ice ages, and their role in divergence and speciation. *Biological Journal of Linnean Society* 58: 247–276.
- Hewitt, G. M. 1999. Post-glacial re-colonization of European biota. *Biological Journal of Linnean Society* 68: 87–112.
- Hewitt, G. M. 2001. Speciation, hybrid zones and phylogeography—seeing genes in space and time. *Molecular Ecology* 10: 537–549.
- Hewitt, G. M. 2004. Genetic consequences of climatic oscillations in the Quaternary. *Philosophical Transactions of the Royal Society B: Biological Sciences* 359: 183–195.
- Ho, S. Y. W. 2007. Calibrating molecular estimates of substitution rates and divergence times in birds. *Journal of Avian Biology* 38: 409–414.
- Ho, S. Y. W. and Phillips, M. J. 2009. Accounting for calibration uncertainty in phylogenetic estimation of evolutionary divergence time. *Systematic Biology* 58: 367–380.
- Hosoda, T., Sato, J. J., Lin, L.-K., Chen, Y.-J., Harada, M. and Suzuki, H. 2011. Phylogenetic history of mustelid fauna in Taiwan inferred from mitochondrial genetic loci. *Canadian Journal of Zoology* 89: 559–569.
- Hosoda, T., Suzuki, H., Harada, M., Tsuchiya, K., Han, S.-H., Zhang, Y.-P., Kryukov, A. P. and Lin, L.-K. 2000. Evolutionary trends of the mitochondrial lineage differentiation in species of genera *Martes* and *Mustela*. *Genes and Genetic Systems* 75: 233–243.
- Hosoda, T., Suzuki, H., Iwasa, M. A., Hayashida, M., Watanabe, S., Tataru, M. and Tsuchiya, K. 1999. Genetic relationships within and between the Japanese marten *Martes melampus* and the sable *Martes zibellina*, based on variation of mitochondrial DNA and nuclear ribosomal DNA. *Mammal Study* 24: 25–33.
- Huelsenbeck, J. P. and Ronquist, F. 2001. MRBAYES: Bayesian inference of phylogenetic trees. *Bioinformatics* 17: 754–755.
- Huelsenbeck, J. P., Ronquist, F., Nielsen, R. and Bollback, J. P. 2001. Bayesian inference of phylogeny and its impact on evolutionary biology. *Science* 294: 2310–2314.
- Imaizumi, Y. 1960. *Colored Illustrations of the Mammals of Japan*. Hoikusha Publishing Co., Ltd., Osaka, 196 pp. (in Japanese).
- Inoue, T., Murakami, T., Abramov, A. V. and Masuda, R. 2010. Mitochondrial DNA control region variations in the sable *Martes zibellina* of Hokkaido Island and the Eurasian continent, compared with the Japanese marten *M. melampus*. *Mammal Study* 35: 145–155.
- Inukai, T. 1975. *Animals in Northernmost Japan* (Hoppou Doubutsushi). Hokuensha, Japan, 152 pp. (in Japanese).
- Iwasa, M. A., Kartavtseva, I. V., Dobrotvorsky, A. K., Panov, V. V. and Suzuki, H. 2002. Local differentiation of *Clethrionomys rutilus* in northeastern Asia inferred from mitochondrial gene sequences. *Mammalian Biology* 67: 157–166.
- Iwasa, M. A., Utsumi, Y., Nakata, K., Kartavtseva, I. V., Nevedomskaya, I. A., Kondoh, N. and Suzuki, H. 2000. Geographic patterns of cytochrome *b* and *Sry* gene lineages in the gray red-backed vole *Clethrionomys rufocanus* from Far East Asia including Sakhalin and Hokkaido. *Zoological Science* 17: 477–484.
- Johnson, N. K. and Cicero, C. 2004. New mitochondrial DNA data affirm the importance of Pleistocene speciation in north American birds. *Evolution* 58: 1122–1130.
- Kadereit, J. W., Griebeler, E. M. and Comes, H. P. 2004. Quaternary diversification in European alpine plants: patterns and process. *Philosophical Transactions of the Royal Society B: Biological Sciences* 359: 265–274.
- Kawamura, Y. 1991. Late Pleistocene to Holocene mammalian faunal succession in the Japanese islands, with comments on the Late Quaternary extinctions. *Archaeozoologia* VI/2: 7–22.
- Koepfli, K.-P., Deere, K. A., Slater, G. J., Begg, C., Begg, K., Grassman, L., Lucherini, M., Veron, G. and Wayne, R. K. 2008. Multigene phylogeny of the Mustelidae: resolving relationships, tempo and biogeographic history of a mammalian adaptive radiation. *BMC Biology* 6: 1–22.
- Korsten, M., Ho, S. Y. W., Davison, J., Pähn, B., Vulla, E., Roht, M., Tumanov, I. L., Kojola, I., Anderson-Lilley, Z., Ozolins, J., Pilot, M., Mertzanis, Y., Giannakopoulos, A., Vorobiev, A. A., Markov, N. I., Saveljev, A. P., Lyapunova, E. A., Abramov, A. V., Männil, P., Valdmann, H., Pazetnov, S. V., Pazetnov, V. S., Rokov, A. M. and Saarma, U. 2009. Sudden expansion of a single brown bear maternal lineage across northern continental Eurasia after the last ice age: a general demographic model for mammals. *Molecular Ecology* 18: 1963–1979.
- Kryukov, A. P. 2010. Comparative phylogeographic patterns of several vertebrates in the East Palearctic. *Moscow University Biological Sciences Bulletin* 65: 184–186.
- Kuroda, N. 1921. On three new mammals from Japan. *Journal of Mammalogy* 2: 208–211.
- Kurose, N., Masuda, R., Siriaroonrat, B. and Yoshida, M. C. 1999. Intraspecific variation of mitochondrial cytochrome *b* gene sequences of the Japanese marten *Martes melampus* and the Sable *Martes zibellina* (Mustelidae, Carnivora, Mammalia) in Japan. *Zoological Science* 16: 693–700.
- Lee, M.-Y., Lissovsky, A. A., Park, S.-K., Obolenskaya, E. V., Dokuchaev, N. E., Zhang, Y.-P., Yu, L., Kim, Y.-J., Voloshina, I., Myslenkov, A., Choi, T.-Y., Min, M.-S. and Lee, H. 2008a. Mitochondrial cytochrome *b* sequence variations and population structure of Siberian chipmunk (*Tamias sibiricus*) in northeastern Asia and population substructure in South Korea. *Molecules and Cells* 26: 566–575.
- Lee, M.-Y., Park, S.-K., Hong, Y.-J., Kim, Y.-J., Voloshina, I., Myslenkov, A., Saveljev, A. P., Choi, T.-Y., Piao, R.-Z., An, J.-H., Lee, M.-H. and Min, M.-S. 2008b. Mitochondrial genetic diversity and phylogenetic relationships of Siberian flying squirrel (*Pteromys vorans*) populations. *Animal Cells and Systems* 12: 269–277.
- Lessa, E. P., Cook, J. A. and Patton, J. L. 2003. Genetic footprints of demographic expansion in North America, but not Amazonia, during the Late Quaternary. *Proceedings of the National Academy of Sciences* 100: 10331–10334.
- Librado, P. and Rozas, J. 2009. DnaSP v5: A software for comprehensive analysis of DNA polymorphism data. *Bioinformatics* 25:

- 1451–1452.
- Lister, A. M. 2004. The impact of Quaternary ice ages on mammalian evolution. *Philosophical Transactions of the Royal Society B: Biological Sciences* 359: 221–241.
- Lovette, I. J. 2005. Glacial cycles and the tempo of avian speciation. *Trends in Ecology and Evolution* 20: 57–59.
- Luthi, D., Floch, M. L., Bereiter, B., Blunier, T., Barnola, J.-M., Siegenthaler, U., Raynaud, D., Jouzel, J., Fischer, H., Kawamura, K. and Stocker, T. F. 2008. High-resolution carbon dioxide concentration record 650,000–800,000 years before present. *Nature* 453: 379–382.
- Malyarchuk, B. A., Derenko, M. V., Berman, D. I., Grzybowski, T., Bulakhova, N. A., Kryukov, A. P. and Lejrih, A. N. 2009. Genetic structure of Schrenck Newt *Salamandrella schrenckii* populations by mitochondrial cytochrome *b* variation. *Molecular Biology* 43: 47–54.
- Malyarchuk, B. A., Petrovskaya, A. V. and Derenko, M. V. 2010. Intraspecific structure of sable *Martes zibellina* L. inferred from nucleotide variation of the mitochondrial DNA cytochrome *b* gene. *Russian Journal of Genetics* 46: 64–68.
- Matsushashi, T., Masuda, R., Mano, T., Murata, K. and Aiurzani, A. 2001. Phylogenetic relationships among worldwide populations of the brown bear *Ursus arctos*. *Zoological Science* 18: 1137–1143.
- Matsushashi, T., Masuda, R., Mano, T. and Yoshida, M. C. 1999. Microevolution of the mitochondrial DNA control region in the Japanese brown bear (*Ursus arctos*) population. *Molecular Biology and Evolution* 16: 676–684.
- Millien-Parra, V. and Jaeger, J.-J. 1999. Island biogeography of the Japanese terrestrial mammal assemblages: an example of a relict fauna. *Journal of Biogeography* 26: 959–972.
- Monakhov, V. G. 2011. *Martes zibellina* (Carnivora: Mustelidae). *Mammalian Species* 43: 75–86.
- Murakami, T. 2001. Species identification of mustelids by comparing partial sequences on mitochondrial DNA from fecal samples. *The Journal of Veterinary Medical Science* 64: 321–323.
- Murakami, T. 2003. Food habits of the Japanese sable *Martes zibellina brachyura* in eastern Hokkaido, Japan. *Mammal Study* 28: 129–134.
- Murakami, T. 2009. *Martes zibellina* (Linnaeus, 1758). In (S. D. Ohdachi, Y. Ishibashi, M. A. Iwasa and T. Saitoh, eds.) *The Wild Mammals of Japan*, pp. 196–197. Shoukadoh, Kyoto.
- Murakami, T., Asano, M. and Ohtaishi, N. 2004. Mitochondrial DNA variation in the Japanese marten *Martes melampus* and Japanese sable *Martes zibellina*. *Japanese Journal of Veterinary Research* 51 (3-4): 135–142.
- Nowak, R. M. 1999. *Walker's Mammals of the World*, 6th ed. The Johns Hopkins University Press, Baltimore, 1936 pp.
- Nylander, J. A. A. 2004. MrModeltest v2. Program distributed by author. Evolutionary Biology Centre, Uppsala University, Uppsala.
- Ohdachi, S., Dokuchaev, N. E., Hasegawa, M. and Masuda, R. 2001. Intraspecific phylogeny and geographical variation of six species of northeastern Asiatic *Sorex* shrews based on the mitochondrial cytochrome *b* sequences. *Molecular Ecology* 10: 2199–2213.
- Ohshima, K. 1990. The history of straits around the Japanese islands in the late-Quaternary. *The Quaternary Research* 29: 193–208 (in Japanese with English abstract).
- Ohshima, K. 1991. The late-Quaternary sea-level change of the Japanese Islands. *Journal of Geography* 100: 967–975 (in Japanese).
- Ohshima, K. 1992. Sea level and coastal morphology through Late Quaternary glacial maximum. *Chishitsu News* 459: 40–48 (in Japanese).
- Ono, Y. 1991. Glacial and periglacial paleoenvironments in the Japanese islands. *The Quaternary Research* 30: 203–211.
- Oshida, T. and Masuda, R. 2000. Phylogeny and zoogeography of six squirrel species of the genus *Sciurus* (Mammalia, Rodentia), inferred from cytochrome *b* gene sequences. *Zoological Science* 17: 405–409.
- Oshida, T., Abramov, A., Yanagawa, H. and Masuda, R. 2005. Phylogeography of the Russian flying squirrel (*Pteromys volans*): implication of refugia theory in arboreal small mammal of Eurasia. *Molecular Ecology* 14: 1191–1196.
- Pavlov, M. P., Korsakova, I. B., Timofeev, V. V. and Safonov, V. G. 1973. Acclimatization of hunting-game mammals and birds in the USSR. Part 1. Kirov. pp. 536 (in Russian).
- Petit, R. J., Aguinagalde, I., de Beaulieu, J.-L., Bittkau, C., Brewer, S., Cheddadi, R., Ennos, R., Fineschi, S., Grivet, D., Lascoux, M., Mohanty, A., Muller-Starch, G., Demesure-Musch, B., Palme, A., Martin, J. P., Rendell, S. and Vendramin, G. G. 2003. Glacial refugia: hotspots but not melting pots of genetic diversity. *Science* 300: 1563–1565.
- Petrovskaya, A. V. 2007. Genetic structure of the sable *Martes zibellina* L. populations from Magadan Oblast as inferred from mitochondrial DNA variation. *Russian Journal of Genetics* 43: 424–429.
- Posada, D. and Buckley, T. R. 2004. Model selection and model averaging in phylogenetics: Advantages of Akaike Information Criterion and Bayesian approaches over likelihood ratio tests. *Systematic Biology* 53: 793–808.
- Posada, D. and Crandall, K. A. 1998. MODELTEST: Testing the model of DNA substitution. *Bioinformatics* 14: 817–818.
- Provan, J. and Bennett, K. D. 2008. Phylogeographic insights into cryptic glacial refugia. *Trends in Ecology and Evolution* 23: 564–571.
- Rambaut, A. and Drummond, A. J. 2007. Tracer v1.5. Available from <http://beast.bio.ed.ac.uk/Tracer>.
- Rogers, A. R. 1995. Genetic evidence for a Pleistocene population explosion. *Evolution* 49: 608–615.
- Ronquist, F. and Huelsenbeck, J. P. 2003. MrBayes 3: Bayesian phylogenetic inference under mixed models. *Bioinformatics* 19: 1572–1574.
- Runck, A. M. and Cook, J. A. 2005. Postglacial expansion of the southern red-backed vole (*Clethrionomys gapperi*) in North America. *Molecular Ecology* 14: 1445–1456.
- Sakka, H., Quere, J. P., Kartavtseva, I., Pavlenko, M., Chelomina, G., Atopkin, D., Bogdanov, A. and Michaux, J. 2010. Comparative phylogeography of four *Apodemus* species (Mammalia: Rodentia) in the Asian Far East: evidence of Quaternary climatic changes in their genetic signature. *Biological Journal of Linnean Society* 100: 797–821.
- Sambrook, J. and Russell, D. W. 2001. *Molecular Cloning: A Laboratory Manual*, 3rd ed. Cold Spring Harbor Laboratory Press, Cold Spring Harbor, New York.
- Sato, J. J., Hosoda, T., Wolsan, M., Tsuchiya, K., Yamamoto, Y. and Suzuki, H. 2003. Phylogenetic relationships and divergence times among mustelids (Mammalia: Carnivora) based on nucleotide sequences of the nuclear interphotoreceptor retinoid binding protein and mitochondrial cytochrome *b* genes. *Zoological Science* 20: 243–264.
- Sato, J. J., Wolsan, M., Minami, S., Hosoda, T., Sinaga, M. H., Hiyama, K., Yamaguchi, Y. and Suzuki, H. 2009b. Deciphering and dating the red panda's ancestry and early adaptive radiation of Musteloidea. *Molecular Phylogenetics and Evolution* 53: 907–922.
- Sato, J. J., Yasuda, S. P. and Hosoda, T. 2009a. Genetic diversity of the Japanese marten (*Martes melampus*) and its implications for the conservation unit. *Zoological Science* 26: 457–466.
- Schirmermeister, L., Siegert, C., Kuznetsova, T., Kuzmina, S., Andreev, A., Kienast, F., Meyer, H. and Bobrov, A. 2002. Paleoenvironmental and paleoclimatic records from permafrost deposits in the

- Arctic region of Northern Siberia. *Quaternary International* 89: 97–118.
- Serizawa, K., Suzuki, H., Iwasa, M. A., Tsuchiya, K., Pavlenko, M. V., Kartavtseva, I. V., Chelomina, G. N., Dkuchaev, E. and Han, S.-H. 2002. A spatial aspect on mitochondrial DNA genealogy in *Apodemus peninsulae* from East Asia. *Biochemical Genetics* 40: 149–161.
- Stewart, J. R. and Lister, A. M. 2001. Cryptic northern refugia and the origins of the modern biota. *Trends in Ecology and Evolution* 16: 608–613.
- Stewart, J. R., Lister, A. M., Barnes, I. and Dalen, L. 2010. Refugia revisited: individualistic responses of species in space and time. *Proceedings of the Royal Society B: Biological Sciences* 277: 661–671.
- Stone, K. D., Flynn, R. W. and Cook, J. A. 2002. Post-glacial colonization of northwestern North America by the forest-associated American marten (*Martes americana*, Mammalia: Carnivora: Mustelidae). *Molecular Ecology* 11: 2049–2063.
- Sugimoto, T., Miyoshi, K., Sakata, D., Nomoto, K. and Higashi, S. 2009. Fecal DNA-based discrimination between indigenous *Martes zibellina* and non-indigenous *Martes melampus* in Hokkaido, Japan. *Mammal Study* 34: 155–159.
- Suzuki, H. 2009. A molecular phylogenetic view of mammals in the “three-story museum” of Hokkaido, Honshu, and Ryukyu Islands, Japan. In (S. D. Ohdachi, Y. Ishibashi, M. A. Iwasa and T. Saitoh, eds.) *The Wild Mammals of Japan*, pp. 261–263. Shoukadoh, Kyoto.
- Svendsen, J. I., Alexanderson, H., Astakhov, V. I., Demidov, I., Dowdeswell, J. A., Funder, S., Gataullin, V., Henriksen, M., Hjort, C., Houmark-Nielsen, M., Hubberten, H. W., Ingolfsson, O., Jakobsson, M., Kjer, K. H., Larsen, E., Lokrantz, H., Lunkka, J. P., Lysa, A., Mangerud, J., Matiouchkov, A., Murray, A., Moller, P., Niessen, F., Nikolskaya, O., Polyak, L., Saarnisto, M., Siegert, C., Siegert, M. J., Spielhagen, R. F. and Stein, R. 2004. Late Quaternary ice sheet history of northern Eurasia. *Quaternary Science Reviews* 23: 1229–1271.
- Tajima, F. 1989. Statistical method for testing the neutral mutation hypothesis by DNA polymorphism. *Genetics* 123: 585–595.
- Tamura, N. 2009. *Sciurus vulgaris* Linnaeus, 1758. In (S. D. Ohdachi, Y. Ishibashi, M. A. Iwasa and T. Saitoh, eds.) *The Wild Mammals of Japan*, pp. 184–185. Shoukadoh, Kyoto.
- Weir, J. T. and Schluter, D. 2004. Ice sheets promote speciation in boreal birds. *Proceedings of the Royal Society B: Biological Sciences* 271: 1881–1887.
- Wolsan, M. 1993. Phylogeny and classification of early European Mustelida (Mammalia: Carnivora). *Acta Theriologica* 38: 345–384.
- Wolsan, M. and Sato, J. J. 2010. Effects of data incompleteness on the relative performance of parsimony and Bayesian approaches in a supermatrix phylogenetic reconstruction of Mustelidae and Procyonidae (Carnivora). *Cladistics* 26: 168–194.
- Wooding, S. and Ward, R. 1997. Phylogeography and Pleistocene evolution in the North American black bear. *Molecular Biology and Evolution* 14: 1096–1105.
- Wozencraft, W. C. 2005. Order Carnivora. In (D. E. Wilson and D. M. Reeder, eds.) *Mammal Species of the World: A Taxonomic and Geographic Reference*, 3rd ed, Volume 1, pp. 532–628. Johns Hopkins Univ. Press, Baltimore, Maryland.
- Yamada, F. 2009. *Lepus timidus* Linnaeus, 1758. In (S. D. Ohdachi, Y. Ishibashi, M. A. Iwasa and T. Saitoh, eds.) *The Wild Mammals of Japan*, pp. 206–207. Shoukadoh, Kyoto.
- Yamada, F., Takaki, M. and Suzuki, H. 2002. Molecular phylogeny of Japanese Leporidae, the Amami rabbit *Pentalagus furnessi*, the Japanese hare *Lepus brachyurus*, and the mountain hare *Lepus timidus*, inferred from mitochondrial DNA sequences. *Genes and Genetic Systems* 77: 107–116.
- Yu, L. and Zhang, Y.-P. 2006. Phylogeny of the caniform Carnivora: evidence from multiple genes. *Genetica* 127: 65–79.
- Zink, R. M., Klicka, J. and Barber, B. R. 2004. The tempo of avian diversification during the Quaternary. *Philosophical Transactions of the Royal Society B: Biological Sciences* 359: 215–220.
- Zwickl, D. J. 2006. Genetic Algorithm approaches for the phylogenetic analysis of large biological sequence datasets under the maximum likelihood criterion. In PhD dissertation. The University of Texas at Austin.

Received 20 April 2011. Accepted 27 June 2011.

Appendix

Samples and DNA sequences used in this study

Taxon	Voucher number ^a	Sampling locality ^b	Accession numbers	Haplotype ^c
<i>Martes americana</i>		Unknown	AY598546 ^e	
<i>Martes foina</i>	HS1753	Gera, Thuringia, Germany	AB564140 ^d	
<i>Martes martes</i>	AK702	Moscow oblast ⁷ , Russia	AB564141 ^d	
<i>Martes melampus</i>	TH398	Yamagata, Iwate, Japan	AB455709 ^e	
<i>Martes zibellina</i>	AK2169	1_Khabarovsk territory, Evoron lake, Russia	AB625980 ^f	Hap9
	AK204	2_Khabarovsk territory, Solnechny district, Russia	AB625981 ^f	Hap1
	AK205	2_Khabarovsk territory, Solnechny district, Russia	AB625982 ^f	Hap1
	AK206	2_Khabarovsk territory, Solnechny district, Russia	AB625983 ^f	Hap1
	AK1309	3_Primorsky territory, Pozharsky district, Sal'da river, Russia	AB625984 ^f	Hap7
	AK1310	3_Primorsky territory, Pozharsky district, Sal'da river, Russia	AB625985 ^f	Hap11
	AK1311	3_Primorsky territory, Pozharsky district, Sal'da river, Russia	AB625986 ^f	Hap6
	AK1312	3_Primorsky territory, Pozharsky district, Sal'da river, Russia	AB625987 ^f	Hap6
	AK1274	4_Primorsky territory, Maksimovka river, Amgu vil., Russia	AB625988 ^f	Hap8
	AK1275	4_Primorsky territory, Maksimovka river, Amgu vil., Russia	AB625989 ^f	Hap2
	AK1276	5_Primorsky territory, Bol'shaya Ussurka river, Mel'nichnoe vil., Russia	AB625990 ^f	Hap1
	AK1277	5_Primorsky territory, Bol'shaya Ussurka river, Mel'nichnoe vil., Russia	AB625991 ^f	Hap1
	AK1278	5_Primorsky territory, Bol'shaya Ussurka river, Mel'nichnoe vil., Russia	AB625992 ^f	Hap1
	AK1279	5_Primorsky territory, Bol'shaya Ussurka river, Mel'nichnoe vil., Russia	AB625993 ^f	Hap1
	AK1280	5_Primorsky territory, Bol'shaya Ussurka river, Mel'nichnoe vil., Russia	AB625994 ^f	Hap1
	AK1281	5_Primorsky territory, Bol'shaya Ussurka river, Mel'nichnoe vil., Russia	AB625995 ^f	Hap1
	AK1282	5_Primorsky territory, Bol'shaya Ussurka river, Mel'nichnoe vil., Russia	AB625996 ^f	Hap1
	AK1283	5_Primorsky territory, Bol'shaya Ussurka river, Mel'nichnoe vil., Russia	AB625997 ^f	Hap6
	AK1284	5_Primorsky territory, Bol'shaya Ussurka river, Mel'nichnoe vil., Russia	AB625998 ^f	Hap1
	AK1292	5_Primorsky territory, Bol'shaya Ussurka river, Mel'nichnoe vil., Russia	AB625999 ^f	Hap8
	AK1293	5_Primorsky territory, Bol'shaya Ussurka river, Mel'nichnoe vil., Russia	AB626000 ^f	Hap6
	AK1324	6_Primorsky territory, Krasnoarmeysky district, Primanka river, Russia	AB626001 ^f	Hap9
	AK1394	6_Primorsky territory, Krasnoarmeysky district, Primanka river, Russia	AB626002 ^f	Hap6
	AK1395	6_Primorsky territory, Krasnoarmeysky district, Primanka river, Russia	AB626003 ^f	Hap1
	AK1396	6_Primorsky territory, Krasnoarmeysky district, Primanka river, Russia	AB626004 ^f	Hap6
	AK1397	6_Primorsky territory, Krasnoarmeysky district, Primanka river, Russia	AB626005 ^f	Hap3
	AK1398	6_Primorsky territory, Krasnoarmeysky district, Primanka river, Russia	AB626006 ^f	Hap8
	AK1399	6_Primorsky territory, Krasnoarmeysky district, Primanka river, Russia	AB626007 ^f	Hap6
	AK1400	6_Primorsky territory, Krasnoarmeysky district, Primanka river, Russia	AB626008 ^f	Hap1
	AK1574	6_Primorsky territory, Krasnoarmeysky district, Primanka river, Russia	AB626009 ^f	Hap11
	AK1575	6_Primorsky territory, Krasnoarmeysky district, Primanka river, Russia	AB626010 ^f	Hap12
	AK1576	6_Primorsky territory, Krasnoarmeysky district, Primanka river, Russia	AB626011 ^f	Hap8
	AK1654	6_Primorsky territory, Krasnoarmeysky district, Primanka river, Russia	AB626012 ^f	Hap1
	AK1655	6_Primorsky territory, Krasnoarmeysky district, Primanka river, Russia	AB626013 ^f	Hap1
	AK1689	6_Primorsky territory, Krasnoarmeysky district, Primanka river, Russia	AB626014 ^f	Hap9
	AK1690	6_Primorsky territory, Krasnoarmeysky district, Primanka river, Russia	AB626015 ^f	Hap6
	AK1691	6_Primorsky territory, Krasnoarmeysky district, Primanka river, Russia	AB626016 ^f	Hap1
	AK1692	6_Primorsky territory, Krasnoarmeysky district, Primanka river, Russia	AB626017 ^f	Hap6
	AK1693	6_Primorsky territory, Krasnoarmeysky district, Primanka river, Russia	AB626018 ^f	Hap6
	AK1694	6_Primorsky territory, Krasnoarmeysky district, Primanka river, Russia	AB626019 ^f	Hap1
	AK739	7_Primorsky territory, Terney district., Sitca river, Russia	AB626020 ^f	Hap8
	AK1210	8_Primorsky territory, Chuguevsky district, Koksharovka vil., Russia	AB626021 ^f	Hap10
	AK1211	8_Primorsky territory, Chuguevsky district, Koksharovka vil., Russia	AB626022 ^f	Hap1
	AK1212	8_Primorsky territory, Chuguevsky district, Koksharovka vil., Russia	AB626023 ^f	Hap10
	AK1213	8_Primorsky territory, Chuguevsky district, Koksharovka vil., Russia	AB626024 ^f	Hap9
	AK1214	8_Primorsky territory, Chuguevsky district, Koksharovka vil., Russia	AB626025 ^f	Hap1
	AK1215	8_Primorsky territory, Chuguevsky district, Koksharovka vil., Russia	AB626026 ^f	Hap9
	AK1216	8_Primorsky territory, Chuguevsky district, Koksharovka vil., Russia	AB626027 ^f	Hap10
	AK1269	8_Primorsky territory, Chuguevsky district, Koksharovka vil., Russia	AB626028 ^f	Hap1

Taxon	Voucher number ^a	Sampling locality ^b	Accession numbers	Haplotype ^g
	AK1285	8_Primorsky territory, Chuguevsky district, Koksharovka vil., Russia	AB626029 ^f	Hap13
	AK1286	8_Primorsky territory, Chuguevsky district, Koksharovka vil., Russia	AB626030 ^f	Hap10
	AK1287	8_Primorsky territory, Chuguevsky district, Koksharovka vil., Russia	AB626031 ^f	Hap8
	AK1288	8_Primorsky territory, Chuguevsky district, Koksharovka vil., Russia	AB626032 ^f	Hap11
	AK1336	8_Primorsky territory, Chuguevsky district, Koksharovka vil., Russia	AB626033 ^f	Hap11
	AK1644	8_Primorsky territory, Chuguevsky district, Koksharovka vil., Russia	AB626034 ^f	Hap1
	AK1645	8_Primorsky territory, Chuguevsky district, Koksharovka vil., Russia	AB626035 ^f	Hap9
	AK1646	8_Primorsky territory, Chuguevsky district, Koksharovka vil., Russia	AB626036 ^f	Hap10
	AK1699	8_Primorsky territory, Chuguevsky district, Koksharovka vil., Russia	AB626037 ^f	Hap11
	AK1700	8_Primorsky territory, Chuguevsky district, Koksharovka vil., Russia	AB626038 ^f	Hap11
	AK1701	8_Primorsky territory, Chuguevsky district, Koksharovka vil., Russia	AB626039 ^f	Hap11
	HS3863	9_Nukabira Onsen, Hokkaido, Japan	AB626040 ^f	Hap5
	HS3864	9_Nukabira Onsen, Hokkaido, Japan	AB626041 ^f	Hap4
	HS3865	9_Nukabira Onsen, Hokkaido, Japan	AB626042 ^f	Hap4
	HS4701	10_Nishiokoppe, Hokkaido, Japan	AB626043 ^f	Hap5
	HS4705	11_Nopporo, Hokkaido, Japan	AB626044 ^f	Hap4
	HS4715	12_Higashimokoto, Hokkaido, Japan	AB626045 ^f	Hap4
	TH43	13_Otoineppu, Hokkaido, Japan	AB626046 ^f	Hap4
	TH44	14_Soeshinai, Horokanai, Hokkaido, Japan	AB626047 ^f	Hap4
	TH53	15_Toikanbetsu, Hokkaido, Japan	AB626048 ^f	Hap4
	TH401	16_Teshio, Hokkaido, Japan	AB455741 ^e	Hap4

^a Voucher numbers are provided with the following abbreviations for collections of DNA or tissue samples, or whole body specimens: AK, Alexey P. Kryukov's collection deposited in the Institute of Biology and Soil Science, Russian Academy of Sciences, Vladivostok, Russia; HS, Hitoshi Suzuki's collection deposited in the Laboratory of Ecology and Genetics, Graduate School of Environmental Earth Science, Hokkaido University, Sapporo, Japan; TH, Tetsuji Hosoda's collection deposited in the Laboratory of Ecology and Genetics, Graduate School of Environmental Earth Science, Hokkaido University, Sapporo, Japan.

^b Numbers before the name of the sampling locality are the same as those in Fig. 1.

^c Sequence published in Delisle and Strobeck (2005).

^d Sequence published in Hosoda et al. (2011).

^e Sequence published in Sato et al. (2009a).

^f Sequence generated in this study.

^g ND2 haplotypes observed in this study.